

UHF Wireless Audio Module **WA-TX-03-R / WA-RX-03-R**



Operation Guide

Version 1.4 (Oct. 2010)

CIRCUIT DESIGN, INC.,

7557-1 Hotaka, Azumino-city
Nagano 399-8303 JAPAN
Tel: + +81-(0)263-82-1024
Fax: + +81-(0)263-82-1016

e-mail: info@circuitdesign.jp
<http://www.circuitdesign.jp>

CONTENTS

GENERAL DESCRIPTION	3
FEATURES	3
APPLICATION	3
SPECIFICATION	4
TERMINAL DESCRIPTION	5
CHANNEL TABLE	7
REMARKS FOR INTEGRATION OF THE RECEIVER ANTENNA ...	7
CONNECTION DIAGRAM	8
BLOCK DIAGRAM	9
DIMENSIONS	11
REGULATORY COMPLIANCE INFORMATION	13
DECLARATION OF CONFORMITY	15
CAUTIONS AND WARNINGS	16
REVISION HISTORY	17

GENERAL DESCRIPTION

The WA-TX-03-R / WA-RX-03-R are 15ch multichannel audio modules that operate in the European harmonized 863 - 865 MHz band. In addition to offering a frequency range sufficient for voice transmission, the compander noise reduction system has a wide dynamic range, enabling transmission of clear audio signals.

As embedded devices, they include nearly all the parts necessary for audio transmission in a small shielding case, making it possible to develop audio transmission equipment in a short time.

FEATURES

- 863 – 865 MHz European Audio band
- 15 channels, 125 kHz steps
- 70 dB dynamic range with built in noise reduction system
- 50 Hz - 13 kHz audio response
- Low power operation
- Adjustable mute level
- Small size for embedding in user equipment
- R&TTE (EN301 357) and RoHS compliant

APPLICATIONS

- Audio guiding in museums
- Tour guide systems
- Wireless conference systems
- Wireless microphone systems for amateur users
- Various audio transmissions
- Voice monitoring

SPECIFICATION

Common

Items	Specification	Remarks
Compatible standard	EN 301 357	R&TTE
Frequency range	863 – 865 MHz	
Number of channels	15	125 kHz step
Emission class	F3E	
Operating distance	50 m	Line-of-sight
S/N ratio	70 dB or more	W/IHF-A Filter
Audio frequency response	50 Hz-13 kHz	+/-3.5 dB
T.H.D	2 %	@AF 1kHz, $\Delta f = 20\text{kHz}$
Emphasis	50 us	
Operating temperature range	0 to 50 °C	

WA-TX-03-R (Transmitter)

Items	Specification	Remarks
Oscillation type	Crystal based PLL oscillation	
RF power	2 mW (e.r.p)	
Frequency stability	+/- 15 kHz	
Noise reduction	Compander	
Spurious emission	1 uW max.	
Deviation	20 kHz	1 kHz @ -25 dBv
AF input level	- 93 to -13 dBv	1 kHz
AF input impedance	20 k Ω or more	
Maximum DC input to AF input	7 V DC max	
Supply voltage	4.2 to 6 V	3.6 to 7 V *1
Consumption current	70 mA	
Dimensions	36 x 26 x 8 mm	Excluding protrusion
Weight	13 g	

*1 Supply voltage: 3.6 to 7V – Possible operating range without meeting full specifications

WA-RX-03-R (Receiver)

Items	Specification	Remarks
Receiver type	Single super heterodyne	
Local oscillator type	Crystal based PLL oscillation	
IF Frequency	10.7 MHz	
Noise reduction system	Expander	
Receiver sensitivity	21 dBuV (- 92 dBm)	S/N 55 dB
Squelch sensitivity	Adjustable	by external VR
AF output level	- 10 dBv	$\Delta f = 20 \text{ kHz}$
AF output impedance	20 k Ω or less	
Supply voltage	3 to 5 V	
Consumption current	45 mA	
Dimensions	36 x 26 x 8 mm	Excluding protrusion
Weight	13 g	

*0 dBv=0.775 V * The data was taken at 25 C unless otherwise specified

TERMINAL DESCRIPTION

WA-TX-03-R transmitter module

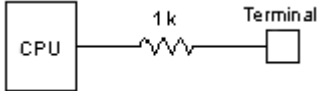
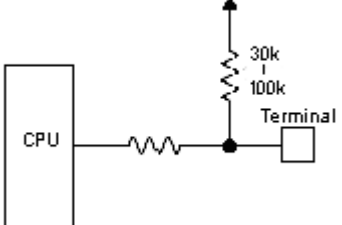
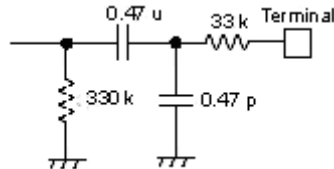
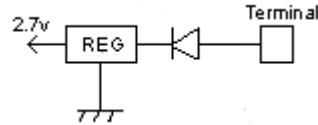
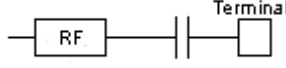
No.	Name	I/O	Description	Equivalent circuit
1	UNA	O	LED terminal for unavailable channels. The terminal is high when any channel outside CH 1 to 15 is selected. LED can be powered directly	
2	SW0	I	Transmitter channel setting terminal Select channel within 15 programmed channels Refer to "Channel table"	
3	SW1	I		
4	SW2	I		
5	SW3	I		
6	NC	-		
7	NC	-		
8	STB	I	Terminal for stand-by with power off delay Set to high to enter standby. Set to ground when transmitting.	
9	AF	I	Audio signal input terminal Audio input signal level -93 dBv to -13 dBv	
10	VCC	I	Power supply (+) terminal Voltage range is DC 4.2 to 6 V A power source without ripple noise should be used. A protection diode for reverse connection is provided in the circuit.	
11	ANT	O	Antenna terminal (RF output) 50 Ω impedance	
12	GND	I	GND terminal The ground is for the power supply and antenna radial. Connect it to a wide ground plane for efficient antenna emissions and stable operation.	

WA-RX-03-R receiver module

CN1

No.	Name	I/O	Description	Equivalent circuit
1	CON	O	Terminal for adjustment of mute level. Connect a 10 to 20 kΩ VR to the terminal for mute level adjustment. The mute level is the threshold level of the received signal field strength so as not to output the received signal below the threshold level.	
2	LED	O	MUTE LED terminal The terminal is high when mute is in operation. It is low when the AF signal is output, so that the LED connecting the terminal works as an AF output indicator showing the AF output status. The terminal is an open collector and is connected to a 220Ω resistor (Max 10mA).	
3	UNA	O	LED terminal for unavailable channels. The terminal is high when any channel other than CH 1 to 15 is selected. The LED can be powered directly	
4	VCC	I	Power supply (+) terminal The voltage range is DC 3.0 to 5 V A power source without ripple noise should be used. Be sure to connect it with the correct polarity. To maintain a lower voltage, a protection diode is not provided in the circuit.	
5	AF	I	Audio output terminal Output impedance is 20 kΩ. Connection to a low input impedance interface will decrease the output level. Maximum output level is -10 dBv When an audio amplifier is used, if the amplified output is distorted by the MIC input, insert an attenuator.	
6	GND		GND terminal The ground is for the power supply and antenna radial. Connect it to a wide ground plane for stable operation.	
7	ANT	I	Antenna terminal (RF input). 50 Ω impedance	

CN2

No.	Name	I/O	Description	Equivalent circuit
1	SW0	I	Receiver channel setting terminal Selects a channel within 15 programmed channels Refer to "Channel table"	
2	SW1	I		
3	SW2	I		
4	SW3	I		
5	NC	-		
6	NC	-		

CHANNEL TABLE

CH	TX/RX frequency	SW0	SW1	SW2	SW3
0	Unavailable	H	H	H	H
1	863.125	L	H	H	H
2	863.250	H	L	H	H
3	863.375	L	L	H	H
4	863.500	H	H	L	H
5	863.625	L	H	L	H
6	863.750	H	L	L	H
7	863.875	L	L	L	H
8	864.000	H	H	H	L
9	864.125	L	H	H	L
10	864.250	H	L	H	L
11	864.375	L	L	H	L
12	864.500	H	H	L	L
13	864.625	L	H	L	L
14	864.750	H	L	L	L
15	864.875	L	L	L	L

L = GND

Remarks for integration of the receiver antenna

Please pay due attention to the design of the antenna ground plane based on the general design theory. Locate the antenna in a place where there are no objects between TX and RX and that is visible from the transmitter antenna. If a PCB pattern line is used for connection between the antenna terminal and the antenna you choose, please secure the following pattern width.

PCB thickness (mm)	0.8	1	1.2	1.6
Pattern width (mm)	1.3	1.4	1.7	2.7

(The example above shows a case where a G10 double-sided PCB is used.)

CONNECTION EXAMPLE (WA-RX-03-R)

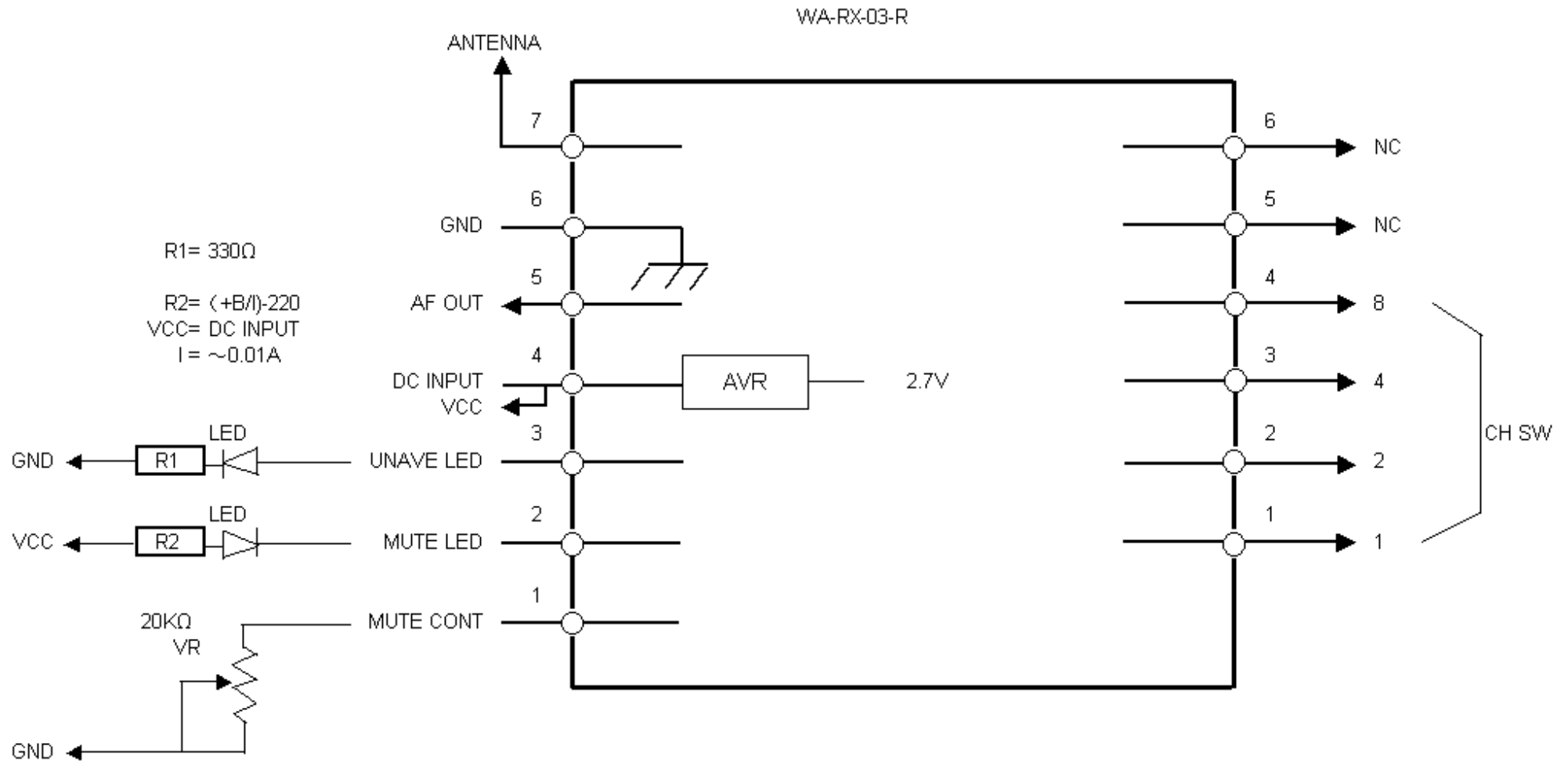

BLOCK DIAGRAM (WA-TX-03-R)

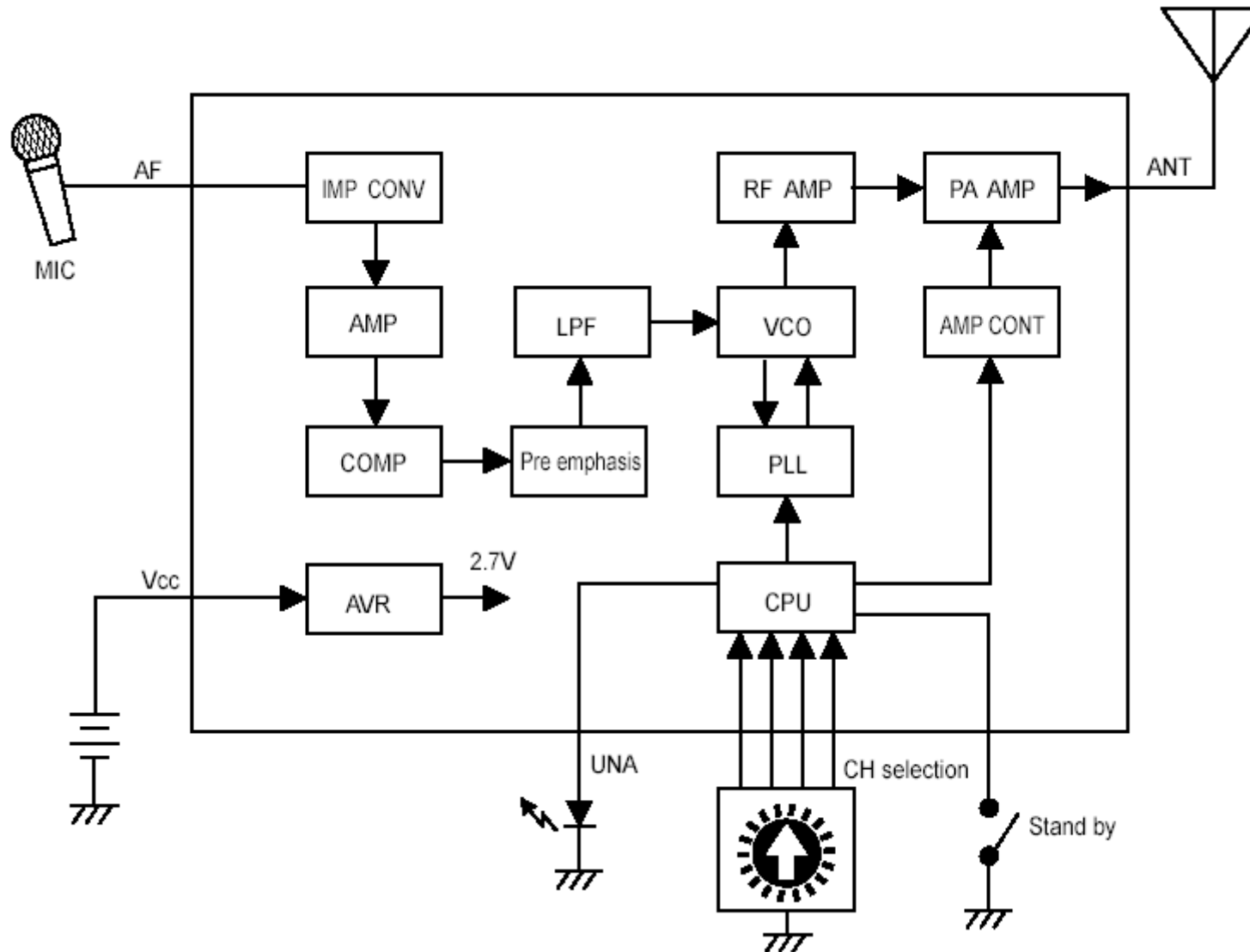

BLOCK DIAGRAM (WA-RX-03-R)

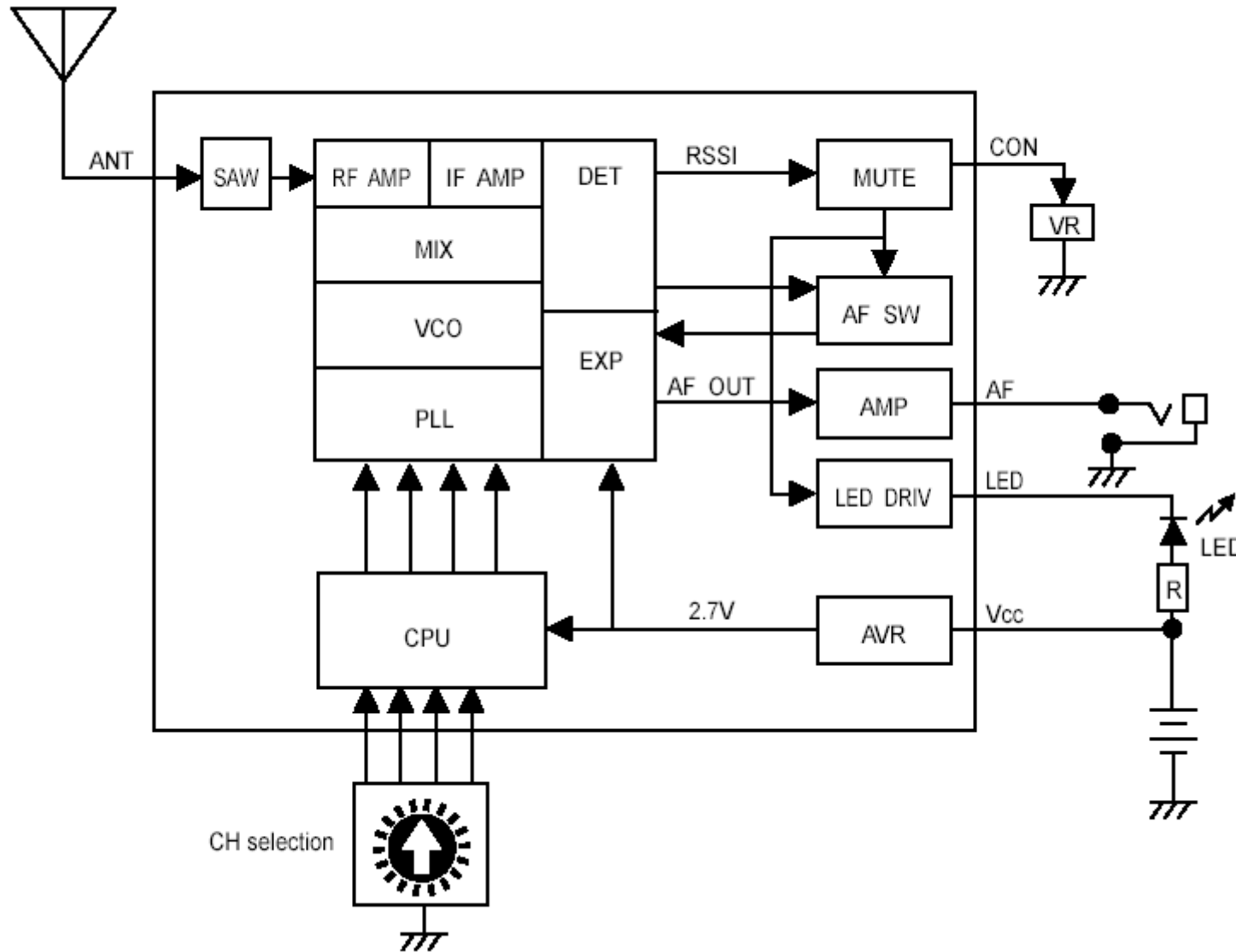

DIMENSION WA-TX-03-R

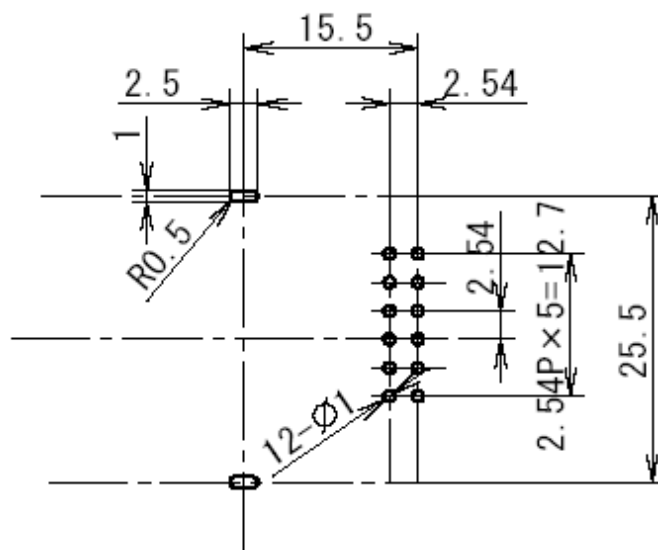
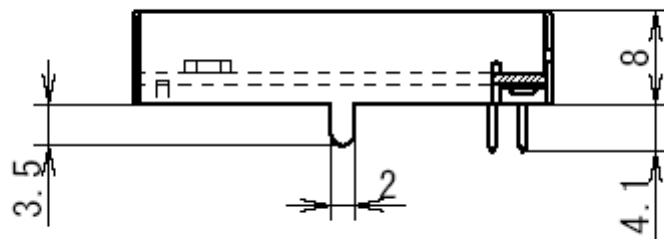
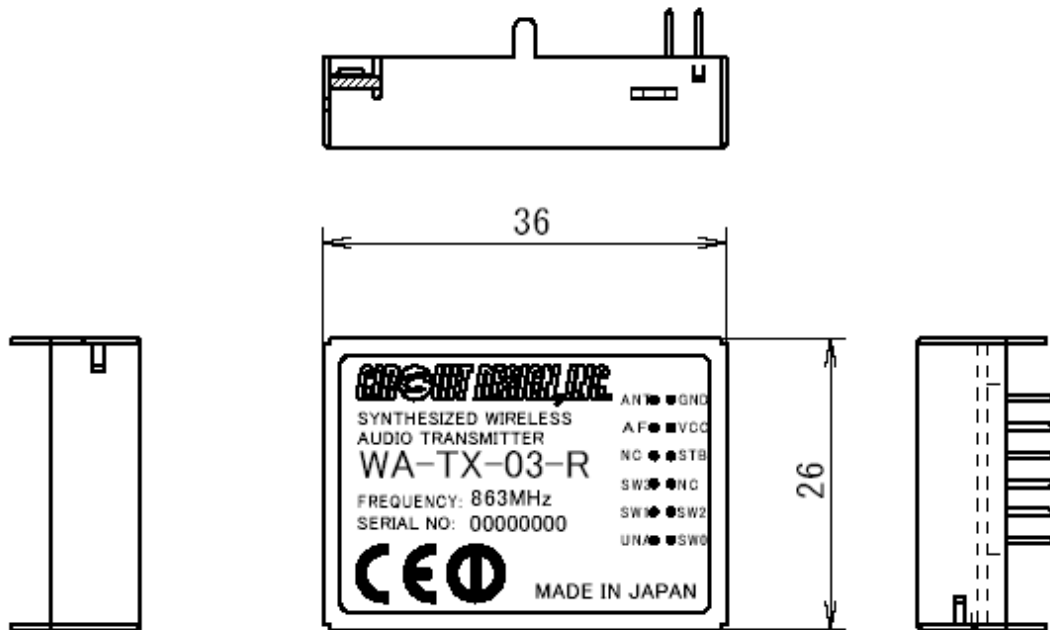

Reference hole position (Top view)

Regulatory Compliance Information

Regulatory compliance of the WA-TX-03-R and the WA-RX-03-R

The WA-TX-03-R and the WA-RX-03-R are designed for embedding in other equipment.

(Products incorporating the WA-TX-03-R and the WA-RX-03-R are henceforward referred to as final products.)

The European regulation applicable to the WA-TX-03-R and the WA-RX-03-R is the R&TTE Directive 1999/5/EC.

The WA-TX-03-R and the WA-RX-03-R are intended to be used for the Radio Microphones defined in the ERC/REC 70-03 Annex 10 and for the Wireless Audio Applications in the ERC/REC 70-03 Annex 13 (EN 301 357*)

The conformity assessment for the WA-TX-03-R and the WA-RX-03-R were completed in accordance with the R&TTE Directive Annex II (RX) & III (TX) procedures, and the Declaration of Conformity is attached to this manual.

* **NOTE:** EN 301 357 defines the equipment covered by its standard and the output power limits depend on the equipment type. The WA-TX-03-R meets the output power limits allowed for all equipment types except for “in-vehicle cordless” and “personal cordless”. If the WA-TX-03-R is used for “in-vehicle cordless” or “personal cordless” equipment, the manufacturer is required to design the final product within the specified output power limit and to perform the conformity assessment of the final product to EN 301 357.

Cautions related to regulatory compliance when embedding WA-TX-03-R/WA-RX-03-R

1. Antenna for the WA-TX-03-R

The WA-TX-03-R is supplied without a dedicated antenna and the user is required to provide an antenna. The conformity assessment of the WA-TX-03-R was performed using Circuit Design’s evaluation board and antenna (1/4 lambda lead antenna). We recommend that you use our standard antenna (ANT-LEA-02 or ANT-RIG-02), or an antenna with equivalent characteristics and performance. For details about our evaluation boards and antennas, refer to www.circuitdesign.jp or contact us. If you use an antenna other than the recommended antenna, further radio conformity assessment may be required.

2. Supply voltage of the WA-TX-03-R

The WA-TX-03-R should be used within the specified voltage range (4.2 V to 6.0 V).

3. Enclosure

To fulfill the requirements of EMC and safety requirements, the WA-TX-03-R and the WA-RX-03-R should be mounted on the circuit boards of the final products and must be enclosed in the cases of the final products. No surface of the WA-TX-03-R and the WA-RX-03-R should be exposed.

4. Cordless audio transmitter shutoff

The WA-TX-03-R does not have automatic transmitter shutoff function in the module. The manufacturer of the final product is required to design the final product to have such function in accordance with EN 301 357.

EMC requirements according to the R&TTE Directive Article 3.1b

The ESD-test (Electro Static Discharge test) was not performed on the WA-TX-03-R and the WA-RX-03-R. The WA-TX-03-R and the WA-RX-03-R are designed for embedding in final products and rely on the enclosures of the final products to provide the necessary protection. The ESD test should be performed on the final products incorporating the WA-TX-03-R and the WA-RX-03-R.

Safety requirements according to the R&TTE Directive Article 3.1a

The WA-TX-03-R and the WA-RX-03-R rely on the final products to provide the electrical, mechanical, and fire enclosure requirements.

The nominal supply voltage of the WA-TX-03-R is 4.2 – 6.0V and the WA-RX-03-R is 3.0 V – 5.0 VDC. The worst input currents under normal operating conditions are 70mA and 45mA respectively. The final product should be capable of supplying these power requirements.

The WA-TX-03-R and the WA-RX-03-R are entirely SELV (Separated Extra Low Voltage) when the supply input from the final product is SELV, i.e. the WA-TX-03-R and the WA-RX-03-R are Class III equipment in which protection against electric shock relies on a supply from an SELV circuit and in which hazardous voltage is not generated.

The WA-TX-03-R and the WA-RX-03-R should be installed in the final products so that the required creepage and clearance distances (within the final products) are maintained.

Conformity assessment of the final product

The manufacturer of the final product is responsible for the conformity assessment procedures of the final product in accordance with the R&TTE Directive.

As to the conformity assessment of the R&TTE Directive Article 3.2 (Efficient use of the radio spectrum), the manufacturer of the final products incorporating the R&TTE assessed WA-TX-03-R and WA-RX-03-R will be exempted from its conformity assessment procedures. For details of how to use the conformity assessment of the WA-TX-03-R and the WA-RX-03-R, please consult the relevant authorities or accredited certification bodies.

Notification of the final product

The notification required by R&TTE Directive Article 6 (4) is not necessary if the final product is used in the harmonized frequency band and is classified as Class-1 equipment. If the final product is not used in the harmonized frequency band and is classified as Class-2 equipment, the manufacturer of the final product has a duty to notify the relevant radio regulatory authorities in the countries where the final product is sold.

Exemption clause

Circuit Design, Inc does not guarantee the accuracy of the above mentioned information about the conformity assessment and notification of the final product. Directives, technical standards, principles of operation and the like may be interpreted differently by the authorities in each country. Also the national laws and restrictions vary with the country. In case of doubt or uncertainty, we recommend that you check with the authorities or official certification organizations of the relevant countries.

DECLARATION OF CONFORMITY

Directive 99/5/EC (R&TTED)

We, Circuit Design, Inc of 7557-1 Hotaka, Azumino-city, Nagano 399-8303, Japan declare under our sole responsibility that the products

WA-TX-03-R multi channel wireless audio transmitter

WA-RX-03-R multi channel wireless audio receiver

To which this declaration relates, are in conformity with the following standards and/or other normative documents.

EN 301 357-1, -2 V1.4.1 (2008-11)

EN 301 489-9 V1.4.1 (2007-11)

EN 60950-1:2006

EN 60065: 2002+A1:2006+Cor.:2007+A11:2008

EN 50371:2002

We hereby declare that all essential radio test suites have been carried out and that the above named products are in conformity to all the essential requirement of Directive 1999/5/EC.

Technical documents relevant to the above equipments can be made available for inspection on application to:

Circuit Design, Inc.

7557-1 Hotaka, Azumino-city, Nagano 399-8303, Japan

Nagano Japan Oct. 13, 2010

Place and date of issue



Masayasu Komiyama

Executive GM Engineering

Important notice

- Customers are advised to consult with Circuit Design sales representatives before ordering. Circuit Design believes the provided information is accurate and reliable. However, Circuit Design reserves the right to make changes to this product without notice.
- Circuit Design products are neither designed nor intended for use in life support applications where malfunction can reasonably be expected to result in significant personal injury to the user. Any use of Circuit Design products in such safety-critical applications is understood to be fully at the risk of the customer and the customer must fully indemnify Circuit Design, Inc for any damages resulting from any improper use.
- As the radio module communicates using electronic radio waves, there are cases where transmission will be temporarily cut off due to the surrounding environment and method of usage. The manufacturer is exempt from all responsibility relating to resulting harm to personnel or equipment and other secondary damage.
- The manufacturer is exempt from all responsibility relating to secondary damage resulting from the operation, performance and reliability of equipment connected to the radio module.

Copyright

- All rights in this operation guide are owned by Circuit Design, Inc. No part of this document may be copied or distributed in part or in whole without the prior written consent of Circuit Design, Inc.

Cautions

- Do not use the equipment within the vicinity of devices that may malfunction as a result of electronic radio waves from the radio module.
- Communication performance will be affected by the surrounding environment, so communication tests should be carried out before actual use.
- Ensure that the power supply for the radio module is within the specified rating. Short circuits and reverse connections may result in overheating and damage and must be avoided at all costs.
- Ensure that the power supply has been switched off before attempting any wiring work.
- The case is connected to the GND terminal of the internal circuit, so do not make contact between the '+' side of the power supply terminal and the case.
- When batteries are used as the power source, avoid short circuits, recharging, dismantling, and pressure. Failure to observe this caution may result in the outbreak of fire, overheating and damage to the equipment. Remove the batteries when the equipment is not to be used for a long period of time. Failure to observe this caution may result in battery leaks and damage to the equipment.
- Do not use this equipment in vehicles with the windows closed, in locations where it is subject to direct sunlight, or in locations with extremely high humidity.
- The radio module is neither waterproof nor splash proof. Ensure that it is not splashed with soot or water. Do not use the equipment if water or other foreign matter has entered the case.
- Do not drop the radio module or otherwise subject it to strong shocks.
- Do not subject the equipment to condensation (including moving it from cold locations to locations with a significant increase in temperature.)
- Do not use the equipment in locations where it is likely to be affected by acid, alkalis, organic agents or corrosive gas.
- Do not bend or break the antenna. Metallic objects placed in the vicinity of the antenna will have a great effect on communication performance. As far as possible, ensure that the equipment is placed well away from metallic objects.
- The GND for the radio module will also affect communication performance. If possible, ensure that the case GND and the circuit GND are connected to a large GND pattern.

Warnings

- Do not take a part or modify the equipment.
- Do not remove the product label (the label attached to the upper surface of the module.) Using a module from which the label has been removed is prohibited.

Copyright 2009, Circuit Design, Inc.

REVISION HISTORY

Version	Date	Description	Remark
1.0	July 2007	The first issue	
1.1	Aug. 2007	Add DOC (Page 15)	
1.2	Feb. 2009	DOC updated, Important notice added	Page 15 & 16
1.3	Jan. 2010	Misdescription corrected in the Dimension drawings	Page 11 & 12
1.4	Oct. 2010	DOC updated	Page 15