

# Wireless audio module test board **WA-TBT/TBR-01**



## **Operation Guide**

**Version 1.1 (May 2003)**

---

**CIRCUIT DESIGN, INC.,**

7557-1 Hotaka, Hotaka-machi,  
Minamiazumi, Nagano 399-8303 JAPAN

Tel: + +81-(0)263-82-1024

Fax: + +81-(0)263-82-1016

e-mail: [cdint@circuitdesign.jp](mailto:cdint@circuitdesign.jp)

<http://www.circuitdesign.jp>

## CONTENTS

GENERAL DESCRIPTION .....	3
FUNCTIONS.....	3
TERMINAL DESCRIPTION .....	3
WA-TBT JUMPER SETTING INSTRUCTION .....	5
CIRCUIT DIAGRAM .....	6
CAUTIONS AND WARNINGS .....	8

## GENERAL DESCRIPTION

This test board is developed to allow the user to evaluate the performance of WA-TX-01 and WA-RX-01 without any additional components.

The board consists of a DC/DC converter, LEDs, a battery case and a module.

This operation guide includes the circuit diagram of the test board. It is free to use this information to incorporate the WA-modules in your system.

## FUNCTIONS

WA-TBT-01 that is used with the WA-TX-01 transmitter operates with 1 x 1.5 V AAA battery. The voltage from the battery is converted from 1.5 V to 3 V by the DC/DC converter (WA-DC-01). The WA-TBT-01 transmits the audio signal using the WA-TX-01 module. WA-TBR-01 receives the signal transmitted from the WA-TX-01 and outputs the audio signal from the board using the WA-RX-01. The WA-TBR-01 has a peak detect LED that shows the maximum allowable level of transmission signal.

The input signal can be attenuated by the input signal adjustment volume VR1 on the WA-TBT-01. There is a reception LED on the WA-TBR-01 to indicate receiving of signals.

**TERMINAL DESCRIPTION**
**WA-TBT-01**

Terminal	I/O	Description
Battery	I	1.5 V AAA battery x 1 Polarity: Instructed on the holder. Warning: There is no circuit to prevent reverse connection. Reverse connection can cause damage to the circuit
CN1	I	Audio input See Jumper setting instruction (Page 5)
SW 1	-	Main switch
POWER ON	O	Power on LED Green LED lights when the power is supplied Min. 0.9 V – Max. 1.7 V
BATT LOW	O	Low voltage warning LED Red LED lights when the battery voltage becomes 1.1 V or less. Please change the battery
VR1	I	Input level attenuation adjustment

**WA-TBR-01**

Terminal	I/O	Description
Battery	I	1.5 V AA battery x 1 Polarity: Instructed on the holder and PCB Warning: There is no circuit to prevent reverse connection. Reverse connection can cause damage to the circuits.
CN1	O	Audio output Use a monaural plug which is 3.5 mm in diameter Polarity: Tip = Hot, Sleeve = GND Connect to the MIC input terminal, which has impedance of 10kohm. Use shielded wires for connection.
CN2	I	DC Input DC 4 –12 V Use a plug, which has inside diameter of 2.1 mm and outside diameter of 5.5 mm. Polarity: center = plus, outer = minus *A diode is included in the circuit to prevent reverse connection of power source. Make sure to connect a power source (4-12 V) or battery which has no ripple noise. *Battery operation will be switched to DC supply operation by inserting a DC plug. * The battery should be removed when DC input is used. DC/DC converter operates when battery is used.
SW1	-	Main switch
POWER LED	O	Power on LED Red LED lights when the power is supplied Min. 0.9 V – Max. 1.7 V from battery or DC power supply 4 – 12 V
BATT LOW	O	Low voltage warning LED The LED lights when the battery voltage becomes 1.1 V or less. Please change the battery (This LED dose not work when the DC INPUT is used)
RECEPTION LED	O	'B' LED lights when RF signal is received. Then audio the signal received from CN1 will be output.

**Warning:** When the transmitter/receiver is turned on/off, a 'pop' sound will occur. If a high-powered amplifier or headphone is used, this noise may cause damage to the system or the human body. Connecting or disconnecting the jack will also generate 'pop' sound. Make sure to connect the jack securely lest it come off during use.

## WA-TBT-01 JUMPER SETTING INSTRUCTION

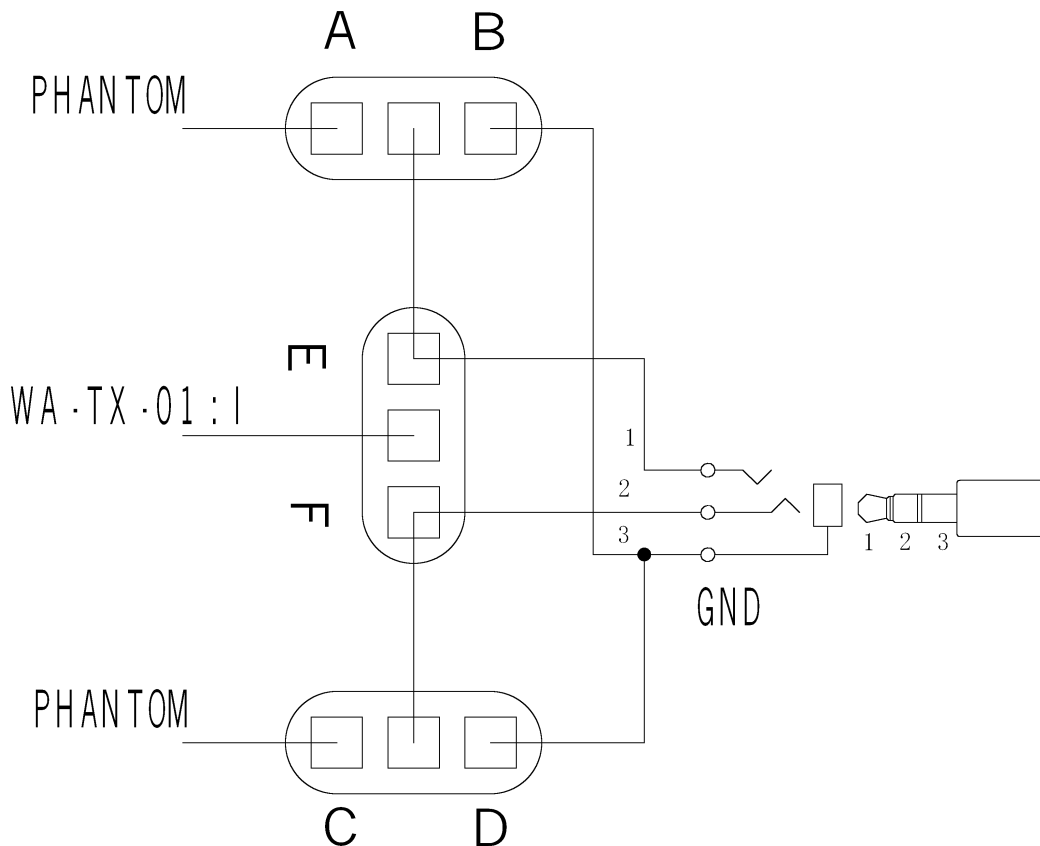

\* PHANTOM: DC3 V

Power supply for the microphone which needs DC power to activate i.e. an electret condenser microphone.

Input signal from :	Jumper
Stereo plug in a power microphone (i.e. electret condenser microphone) and use it with mixed Lch and Rch signal	A, C, E and F
Stereo plug in a power microphone and use it with Lch only.	A and E
Stereo plug in a power microphone and use it with Rch only	C and F
Mono 2pin plug in a power microphone	A, E and D
Mono 3pin plug in a power microphone	A and E
Mono dynamic microphone	E
Stereo signal from the audio recording equipment such as MD or CD player	E and F

Above description is only for reference.

Please carefully check your system and the input signal that will be connected to the WA-TBT-01 against the circuit diagram in this document.

## CIRCUIT DIAGRAM WA-TBT-01

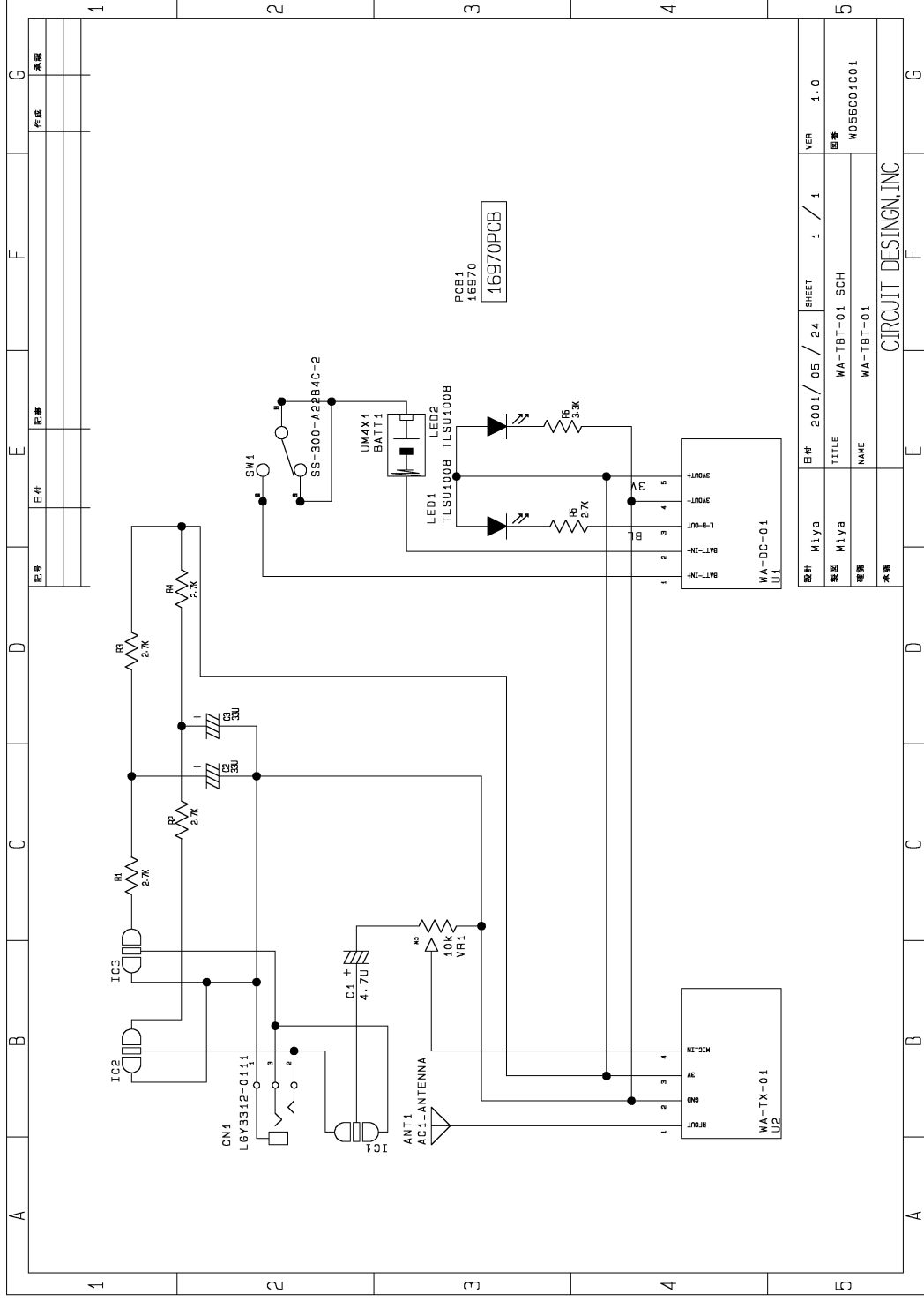

## CIRCUIT DIAGRAM WA-TBR-01

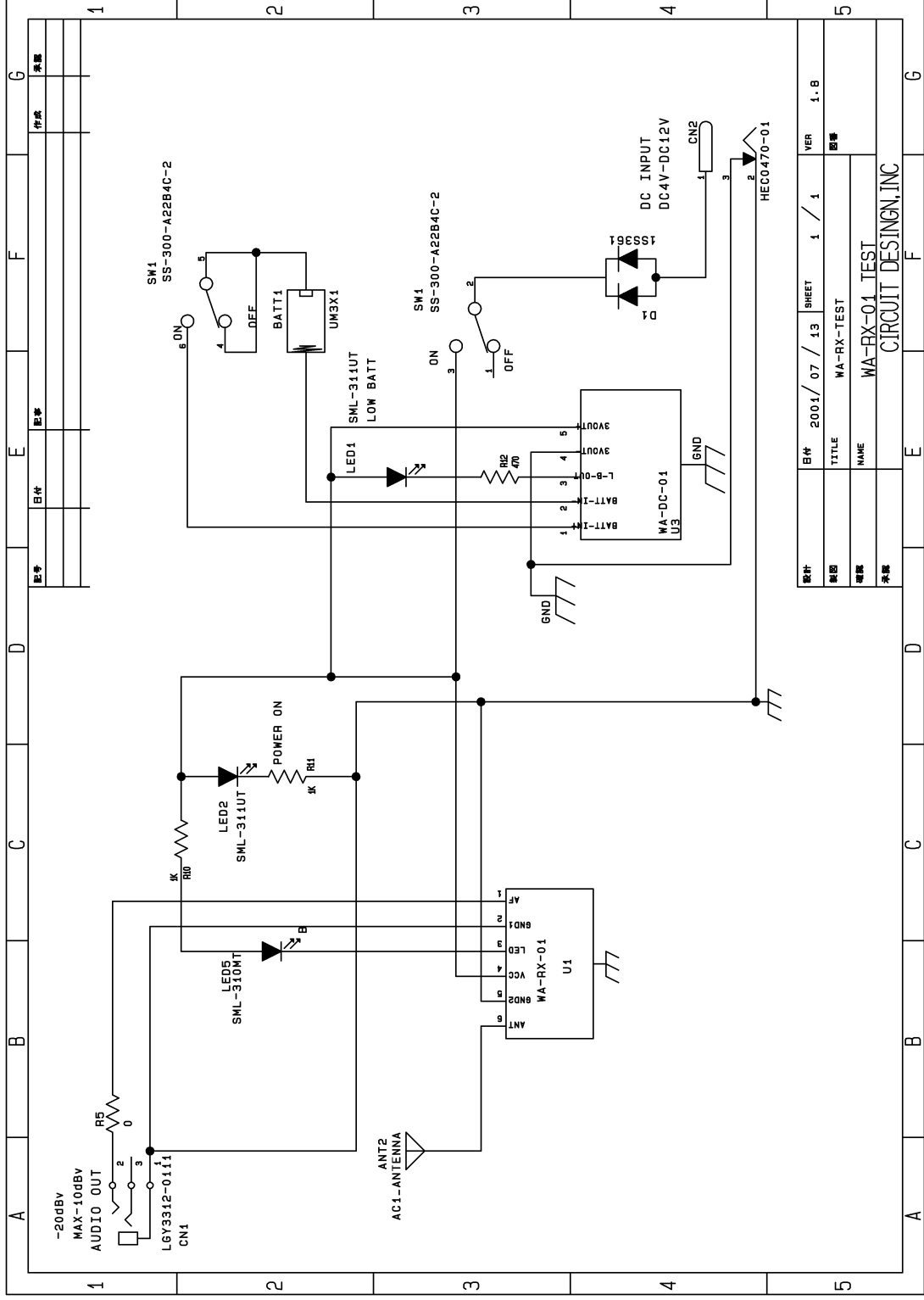

設計	設計	2001/07/13	SHEET	1 / 1	VER	1. B
製図	TITLE	WA-RX-TEST	図番			
確認	NAME	WA-RX-01 TEST	図名			
承認	CIRCUIT DESIGN, INC					

## Cautions

- As the radio module communicates using electronic radio waves, there are cases where transmission will be temporarily cut off due to the surrounding environment and method of usage. The manufacturer is exempt from all responsibility relating to resulting harm to personnel or equipment and other secondary damage.
- Do not use the equipment within the vicinity of devices that may malfunction as a result of electronic radio waves from the radio module.
- The manufacturer is exempt from all responsibility relating to secondary damage resulting from the operation, performance and reliability of equipment connected to the radio module.
- Communication performance will be affected by the surrounding environment, so communication tests should be carried out before actual use.
- Ensure that the power supply for the radio module is within the specified rating. Short circuits and reverse connections may result in overheating and damage and must be avoided at all costs.
- Ensure that the power supply has been switched off before attempting any wiring work.
- The case is connected to the GND terminal of the internal circuit, so do not make contact between the '+' side of the power supply terminal and the case.
- When batteries are used as the power source, avoid short circuits, recharging, dismantling, and pressure. Failure to observe this caution may result in the outbreak of fire, overheating and damage to the equipment. Remove the batteries when the equipment is not to be used for a long period of time. Failure to observe this caution may result in battery leaks and damage to the equipment.
- Do not use this equipment in vehicles with the windows closed, in locations where it is subject to direct sunlight, or in locations with extremely high humidity.
- The radio module is neither waterproof nor splash proof. Ensure that it is not splashed with dirt or water. Do not use the equipment if water or other foreign matter has entered the case.
- Do not drop the radio module or otherwise subject it to strong shocks.
- Do not subject the equipment to condensation (including moving it from cold locations to locations with a significant increase in temperature.)
- Do not use the equipment in locations where it is likely to be affected by acid, alkalis, organic agents or corrosive gas.
- Do not bend or break the antenna. Metallic objects placed in the vicinity of the antenna will have a significant effect on communication performance. As far as possible, ensure that the equipment is placed well away from metallic objects.
- The ground for the radio module will also affect communication performance. If possible, ensure that the case ground and the circuit ground are connected to a large ground pattern.

## Warnings

- Do not take apart or modify the equipment.
- Do not remove the product label (the label attached to the upper surface of the module.) Using a module from which the label has been removed is prohibited.

### **Circuit Design, Inc. All rights reserved**

No part of this document may be copied or distributed in part or in whole without the prior written consent of Circuit Design, Inc.

Customers are advised to consult with Circuit Design sales representatives before ordering.

Circuit Design, Inc. believes the information provided is accurate and reliable. However, Circuit Design, Inc. reserves the right to make changes to this product without notice.